



规格承认书

SPEC FOR APPROVAL

客户名称 Customer	
客户料号 Customer P/N	
我司型号 Model	SK-PT2835-H8
编制日期 Edit Date	2016-08-18

客户确认(Customer Signatures)		
编制(Edit)	审核(Check)	核准(Approval)

产品外形尺寸 Package outline dimensions

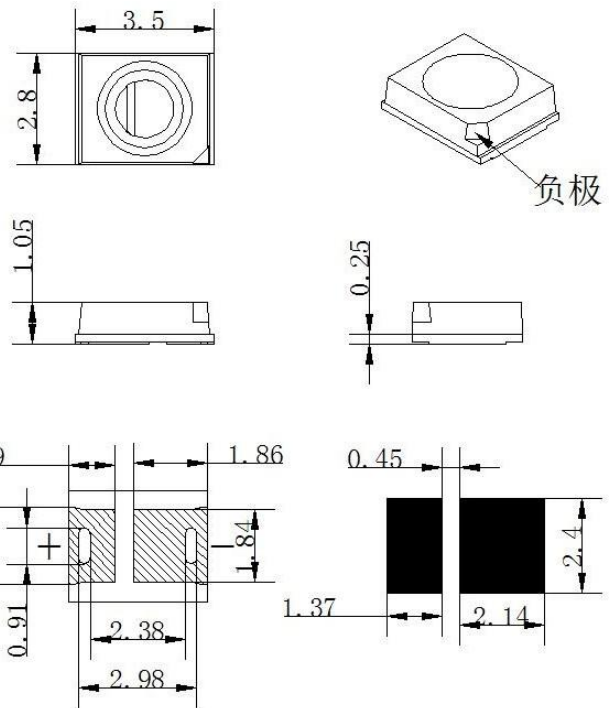
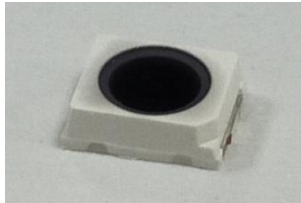

备注：所有尺寸单位均为 mm，如无特殊说明误差范围为±0.15mm

PT 环境光传感器是一款高灵敏度的光敏传感器，是传统 CDS 光敏电阻的理想替代产品，模拟人眼感光，专用于红外监控类产品，控制红外灯低照度下开启。

PT Environmental Light Sensor is a high sensitivity photosensitive sensor, is the ideal alternative for the traditional CDS photomistor, simulate human eye photosensitive, dedicated to infrared monitoring products, control the infrared light under low illumination open.

特性 Features

- 1) 低功耗 Low Power Consumption
- 2) 高可靠性、一致性好 High reliability and good consistency
- 3) 随光照线性变化 Linear change with the light
- 4) 环保，符合 RoHS 、REACH RoHS compliant
- 5) 感光峰值波长 560nm, 感应波长 400-700nm Photosensitive peak wavelength $\lambda_p=850\text{nm}$, Induction wavelength: 400 - 700nm

应用 Application

- 1) 替代传统 CDS 光敏电阻 Replacement of conventional CDS photosensitive resistors
- 2) 适用于各类光控照明产品：如小夜灯等 Suitable for all kinds of light products: such as night lamp etc.
- 3) 自动调节背景光 Automatic adjust background light
- 4) 控制各类光控影控玩具 Control all kinds of light and shadow controlled toys
- 5) 各类光控红外检测测试设备等 All kinds of infrared light detection and testing equipment

额定参数 Absolute Maximum Ratings (Ta=25°C)

电气特性 Electrical characteristics	符号 Symbol	额定值 Rated Value		单位 Unit
工作电压 Operating voltage	Vcc	Min.	Max.	V
		1	13	V
功耗 Power Dissipation	PC	70		mW
工作温度 Operating Temperature	Topr	-30--+85		°C
储存温度 Storage Temperature	Tstg	-40--+100		°C

光电特性 Elector-Optical Characteristics (Ta=25°C)

参数 Parameter	符号 Symbol	测试条件 Test Condition	最小值 Min	典型 Typ	最大值 Max.	单位 Unit
感光峰值波长 Photosensitive peak wavelength	λ_p	\	--	550	--	nm
感光波宽范围 Sensitivity wave width	λ	\	400	--	700	nm
工作电压 Operating voltage	Vcc	\	--	5	--	V
光电流 Photo-current	IL(1)	Vcc=5V Ev=10Lux	1.5	3.5	6.5	μ A
	IL(2)	Vcc=5V Ev=30Lux	7.5	10.5	15.0	μ A
	IL(3)	Vcc=5V Ev=100Lux	20	35	50	μ A
暗电流 dark current	Iceo	Vcc=5V/85°C Ev=0Lux	--	--	0.4	μ A
红外接收电流 Infrared Light Current	IIR	Vcc=5V/850nm IR led Ee=1mW/c m ²	--	--	0.1	μ A
开启时间 Rise time	tr	Vcc=5V IC=1mA RL=1000 Ω	4.5			ms
关闭时间 Fall time	tf		4.5			

温度与暗电流变化图 Environment Temperature VS Dark Current

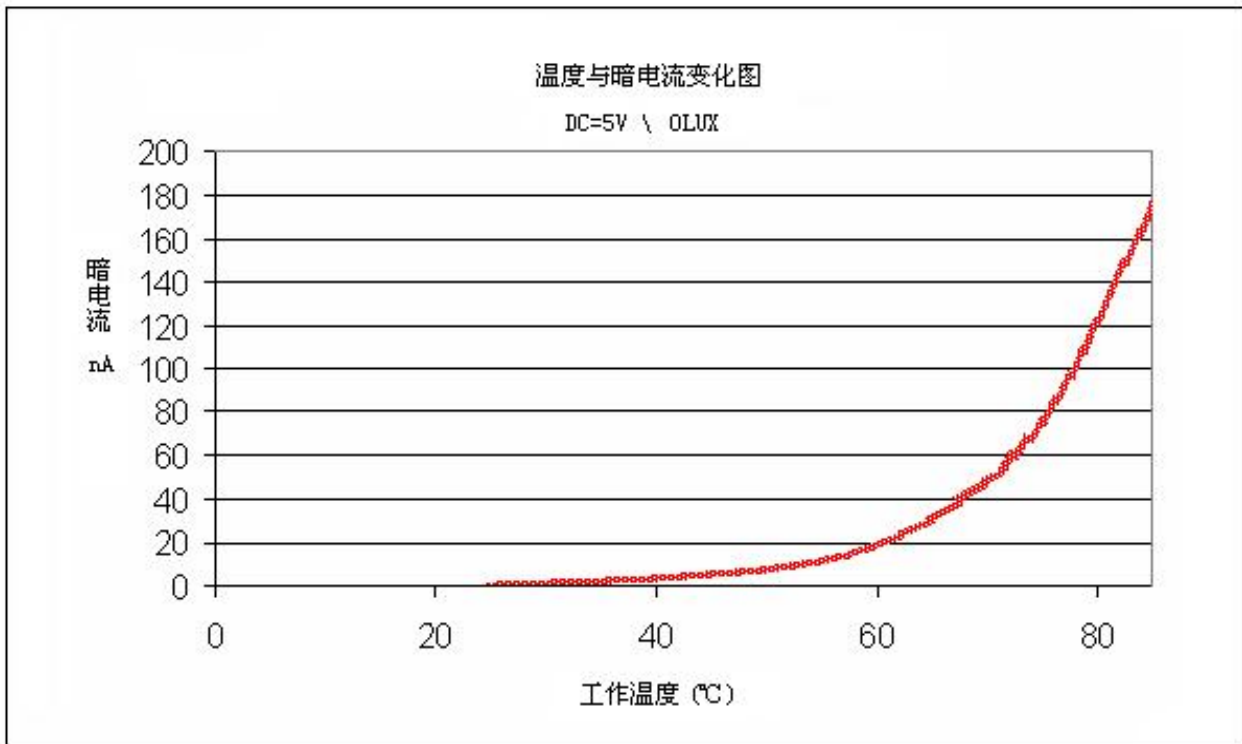

光电特性曲线 Typical photoelectric characteristics curves

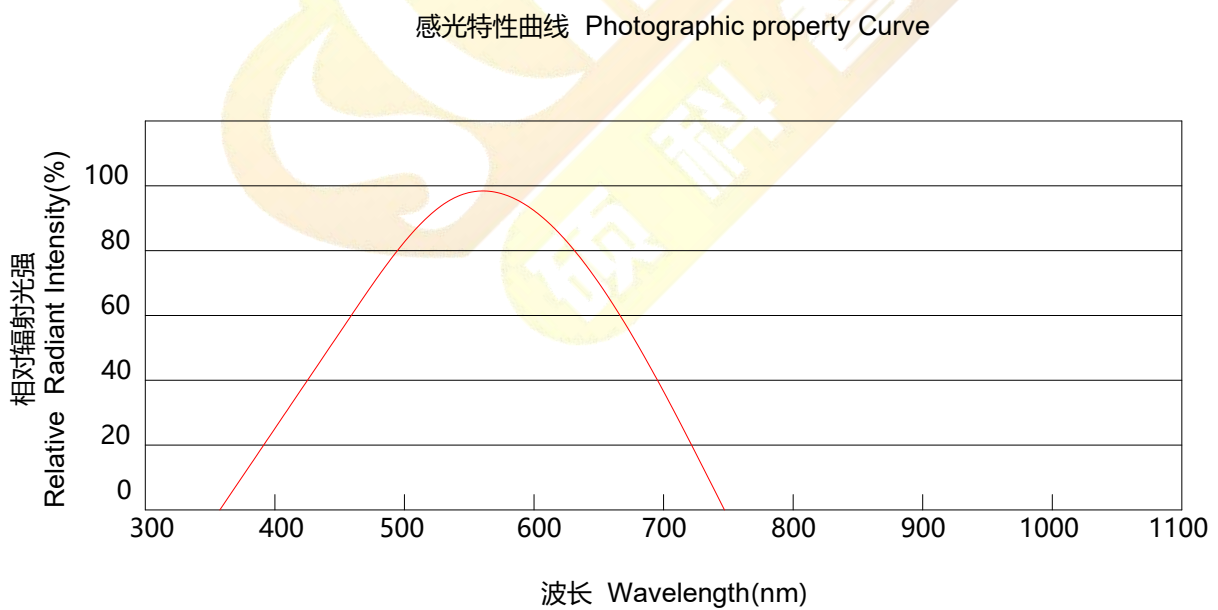

相对灵敏度

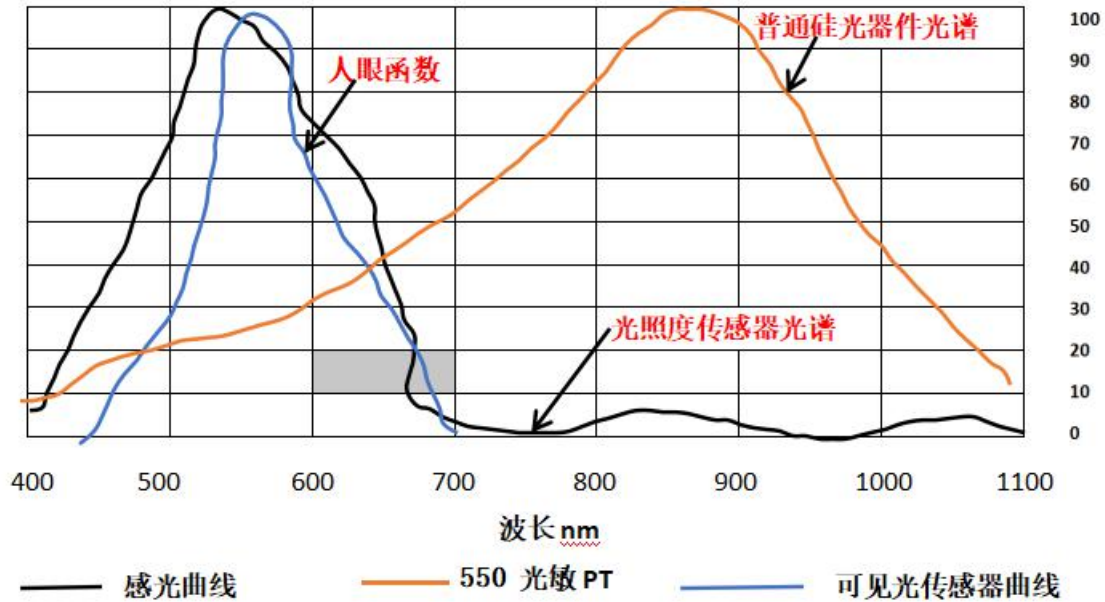

可靠性试验 Reliability Test

测试项目 Test Parameter	测试条件 Test Condition	时间 Time	样品数 Quantity	Ac/Re
耐焊接热 Resistance to Solder Heat	260°C±5°C	10 sec	22PCS	0/1
冷热循环 temperature cycle	+100°C(15min) 5min -10°C(15min)	50 cycles	22PCS	0/1
冷热冲击 Thermal Shock	+105°C(30min) 5min -45°C(30min)	50 cycles	22PCS	0/1
高温贮存 High Temperature storage	+100°C	1000H	22PCS	0/1
低温贮存 Low Temperature storage	-40°C	1000H	22PCS	0/1
寿命测试 Life Test	V _{CE} =5V	1000H	22PCS	0/1
高温高湿 High Temperature and High Humidity Test	85°C&85%R.H	168H	22PCS	0/1

一般应用示意图

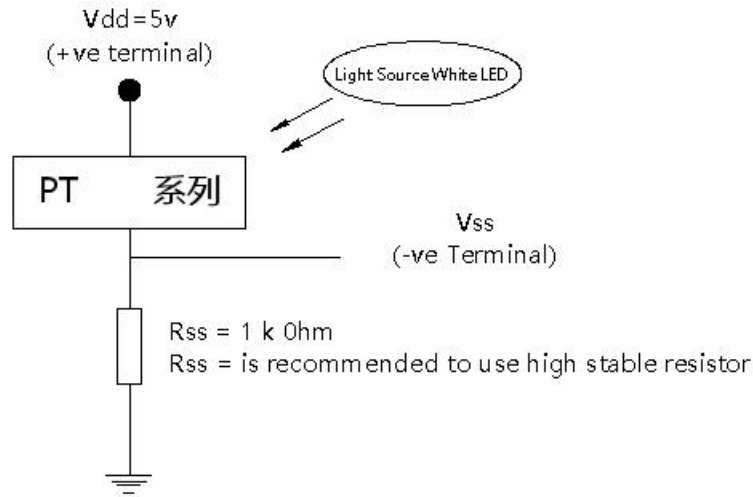

LED通用驱动电路

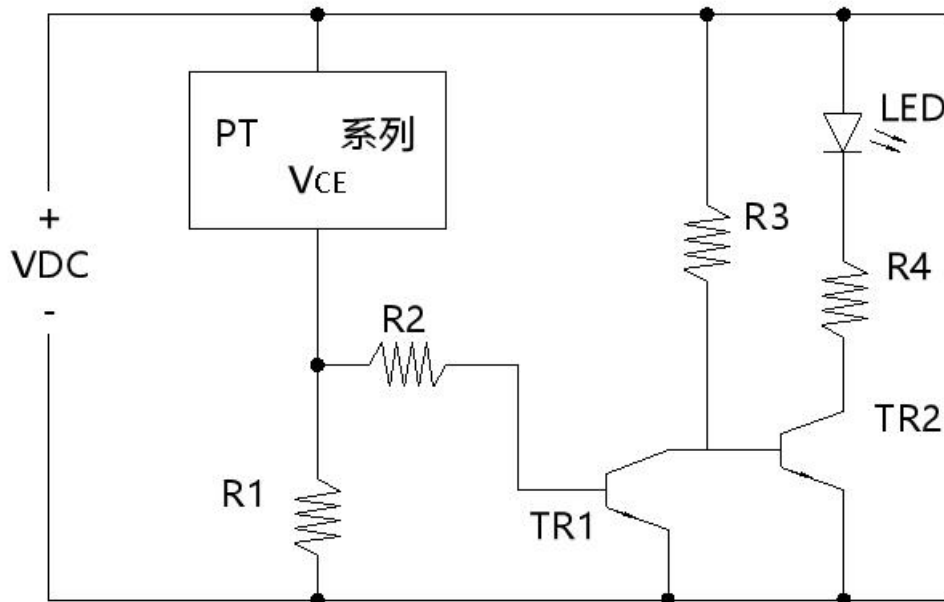

当光照低于光照阈值时，TR1三极管关闭，TR2三极管导通，LED导通。当环境光照大于光照阈值时，TR1降低的电流并使TR2截止，LED不导通。

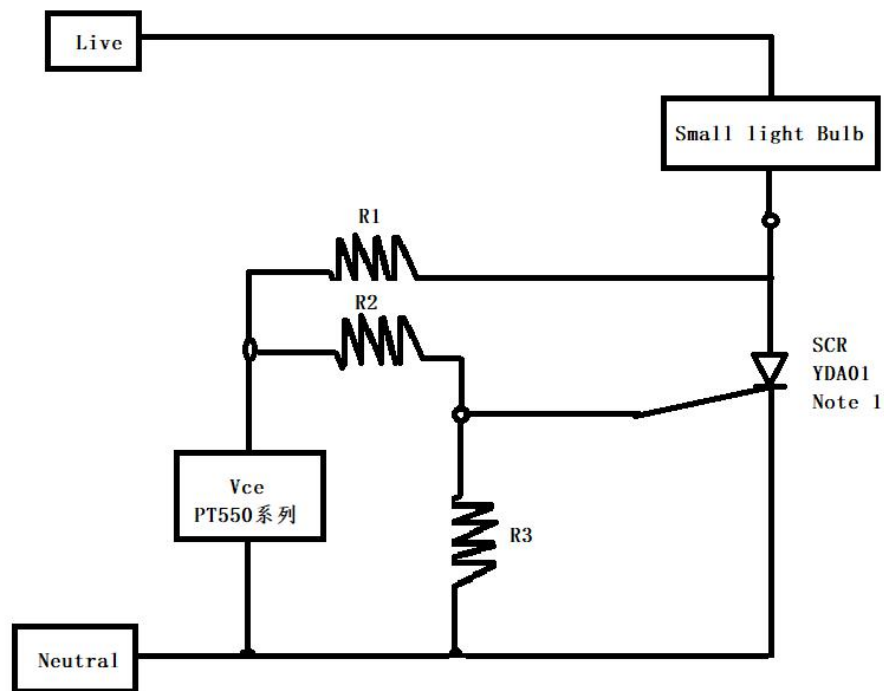

该电路需要一个敏感的可控硅，灯的电流是由敏感的可控硅开关控制，当光量超过阈值时，该VC与引脚之间的电流转移了可控硅的栅极电流，光切换阈值可通过选择R2和R3不同的值进行调整

推荐焊接条件 Recommended Soldering Conditions

焊接模式 Mode		固定形式 Fixed form
手工焊接 Manually Soldering	烙铁温度 Soldering Iron Temperature	最高温度 300°C(功率最大 30 瓦) 300°C Max(30w Max)
	焊接时间 Soldering Time	时间不超过 3 秒 3 sec Max
	焊接位置 Soldering Position	大于 3mm (从焊点到胶体) 3mm Min.(Form soldering joint to colloid)
波峰焊接 Wave Soldering	预热 Preheat	最高温度 100°C 不超过 60 秒 100°C Max.60 sec.Max
	温度 Temperature	最高 250°C 250°C Max.
	焊接时间 Soldering Time	不超过 5 秒 5 sec Max
<ul style="list-style-type: none"> ● 本产品不适合做回流焊接。 ● 手工焊接只可焊接一次。 		